

PLAN

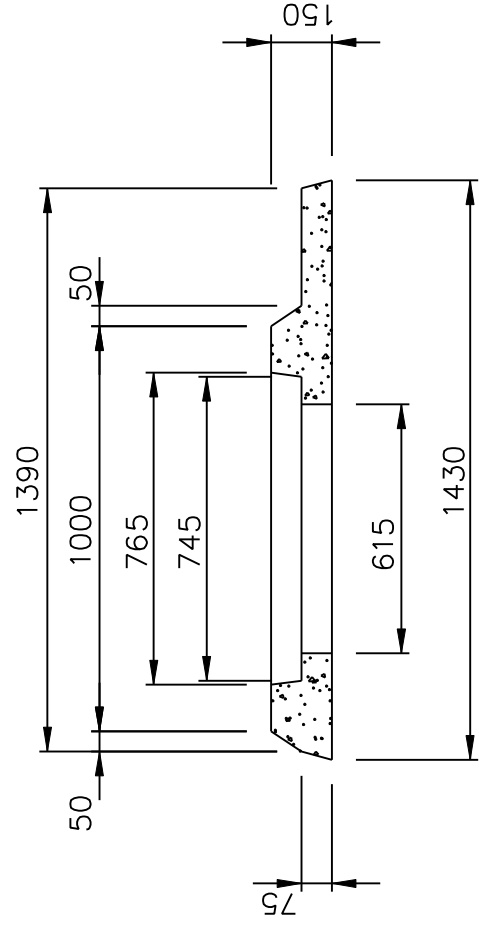

760 DIA CONCRETE COVER  
( GATIC TYPE )

OFFSET MANHOLE COVER AND SURROUND

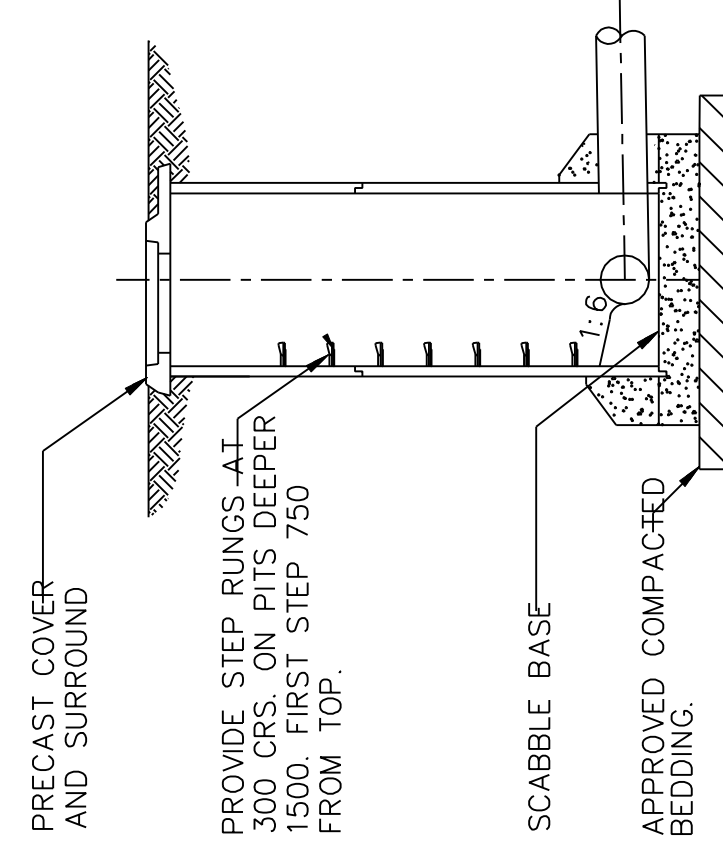
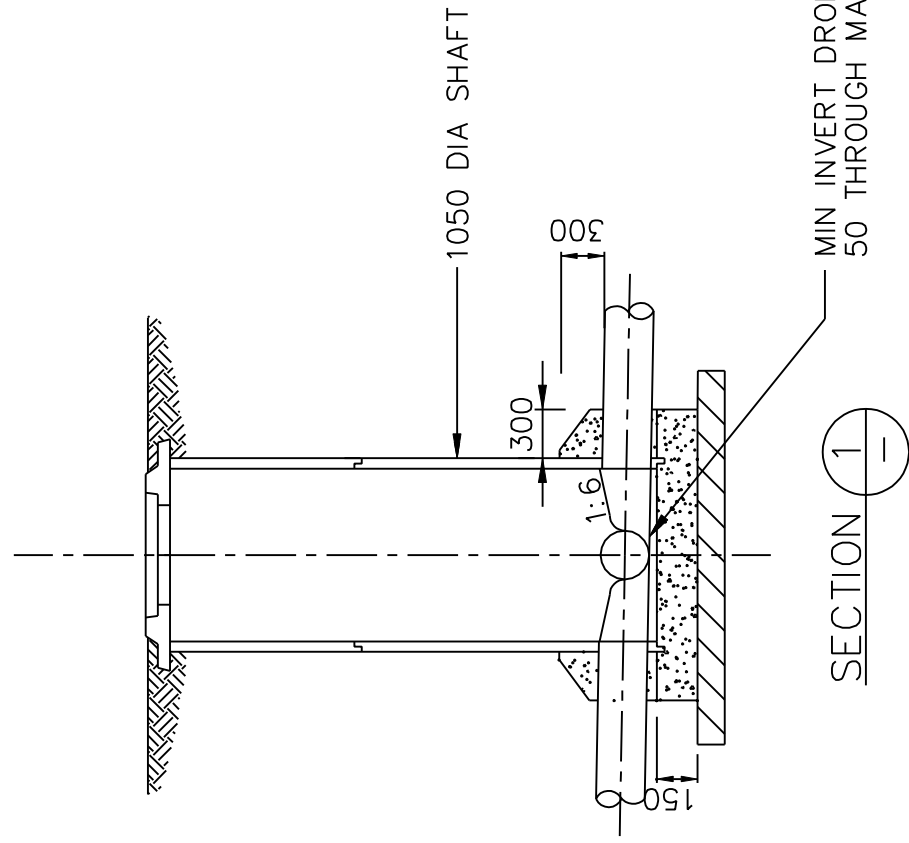

NOTES

1. ALL DIMENSIONS IN MILLIMETRES (mm).
2. INSITU CONCRETE SHALL BE GRADE N20
3. ALTERNATIVE MATERIALS MAY BE USED SUBJECT TO THE APPROVAL OF THE AUTHORISED OFFICER.
4. WHERE MANHOLE IS SUBJECT TO TRAFFIC WHEEL LOADINGS, A HEAVY DUTY COVER AND SURROUND SHALL BE PROVIDED.
5. ALL JOINTS IN MANHOLE SHAFT TO BE PROVIDED WITH A WATERTIGHT SEAL TO THE AUTHORISED OFFICERS APPROVAL.
6. ALL MANHOLE COVERS TO HAVE THE LETTERS "SW" CAST IN TO INDICATE STORMWATER.
7. CONCRETE FILLED GATIC COVERS ARE TO BE PROVIDED WHERE DIRECTED BY AUTHORISED OFFICER.  
CONCRETE INFILL SHALL BE:  
-1 PART CEMENT  
-2 PARTS SAND  
-4 PARTS 10mm SCREENINGS.

(E)			
(D)			
(C)			
(B)			
(A)	REVIEW OF STANDARD DRAWING SET	01/03	Date
No.	Amendment	Appr.	Date

INSTITUTE OF PUBLIC WORKS ENGINEERING AUSTRALIA  
TASMANIA DIVISION Inc. - 2003 DISCLAIMER.  
The authors and sponsoring organisations shall have no liability or responsibility to the user or any other person or entity with respect to any liability, loss or damage caused or alleged to be caused, directly or indirectly, by the adoption and use of these Standard Drawings including, but not limited to, any interruption of service, loss of business or anticipatory profits, or consequential damages resulting from the use of these Standard Drawings. Persons must not rely on these Standard Drawings as equivalent of, or a substitute for, project-specific design and assessment by an appropriately qualified professional.

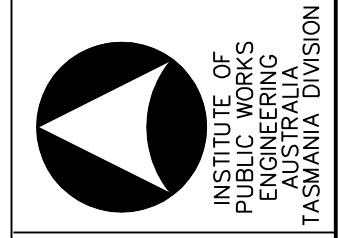

Drawing Title		MUNICIPAL STANDARD DRAWING	
Scale		NOT TO SCALE	
Issue Date	Approved	Issue Date	Approved
NOV. 1997		NOV. 1997	
Drawing No.		SD-2002	
STORMWATER - PRECAST MANHOLE (WITH OFFSET COVER)			